

REVISION STATUS - ALL SHEETS ARE THE SAME REVISION				
ZONE	REV.	DESCRIPTION	DATE	APPROVED
	X1	DEVELOPMENT	07/28/2013	KRH

NOTES: UNLESS OTHERWISE SPECIFIED

- 1 MATERIAL: FOR PART MATERIALS REFERENCE SEPARATE PART DRAWINGS.
- 2 ALL DIMENSIONS ARE TO THEORETICAL SHARP.
- 3 REMOVE BURRS AND BREAK ALL SHARP EDGES .03 MAX.
- 4 ALL DIMENSIONS ARE IN INCHES UNLESS STATED OTHERWISE.
- 5 PARTS SHALL BE FREE OF GREASE AND CUTTING FLUID.
- 6 POWDER COAT PER MIL-PRF-24712A (TYPE 3, CLASS 3)

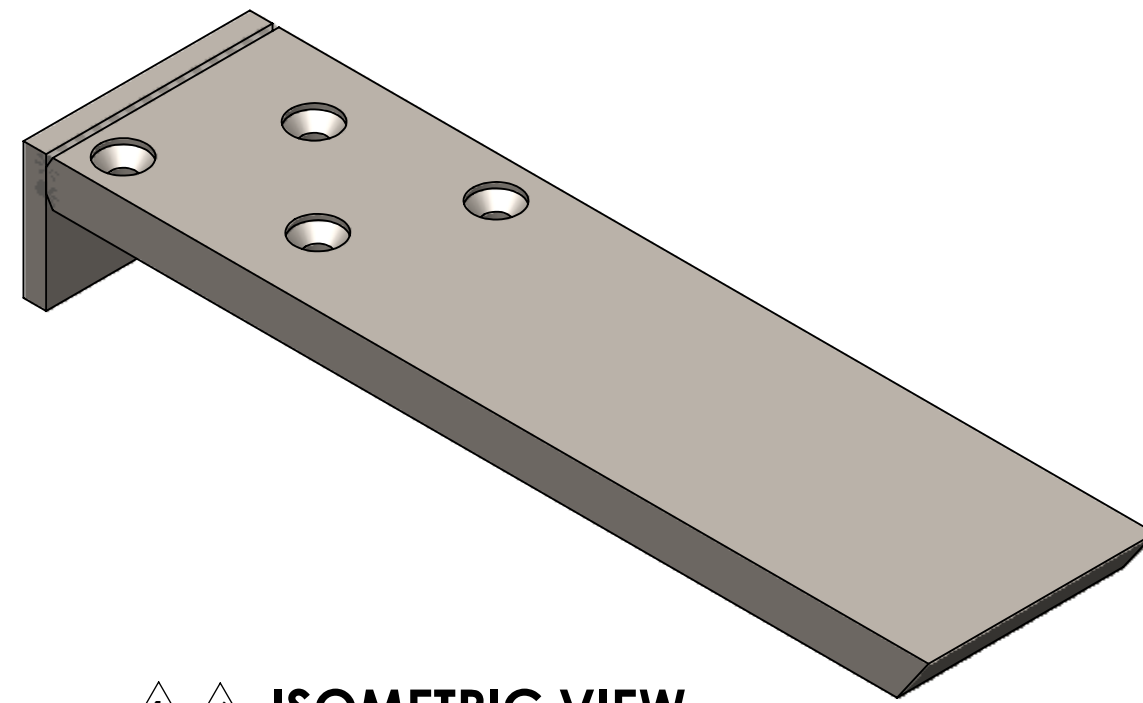

ISOMETRIC VIEW  
FOR REFERENCE ONLY

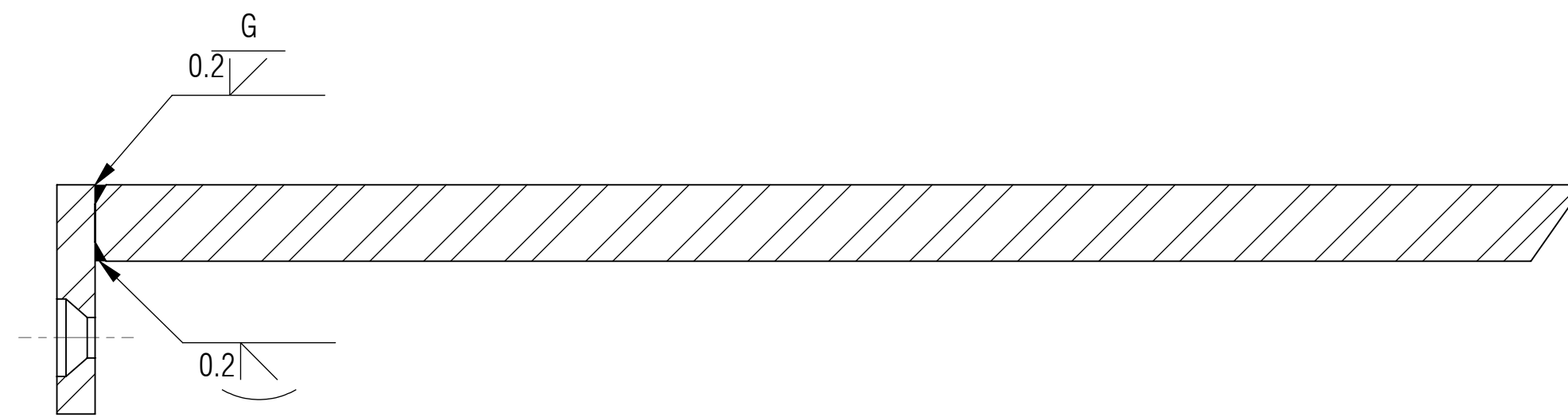
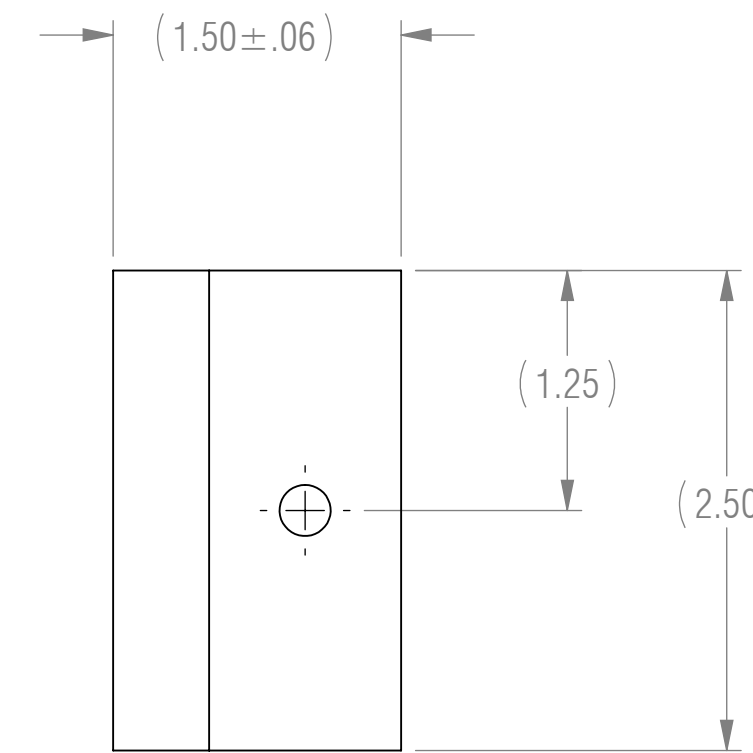
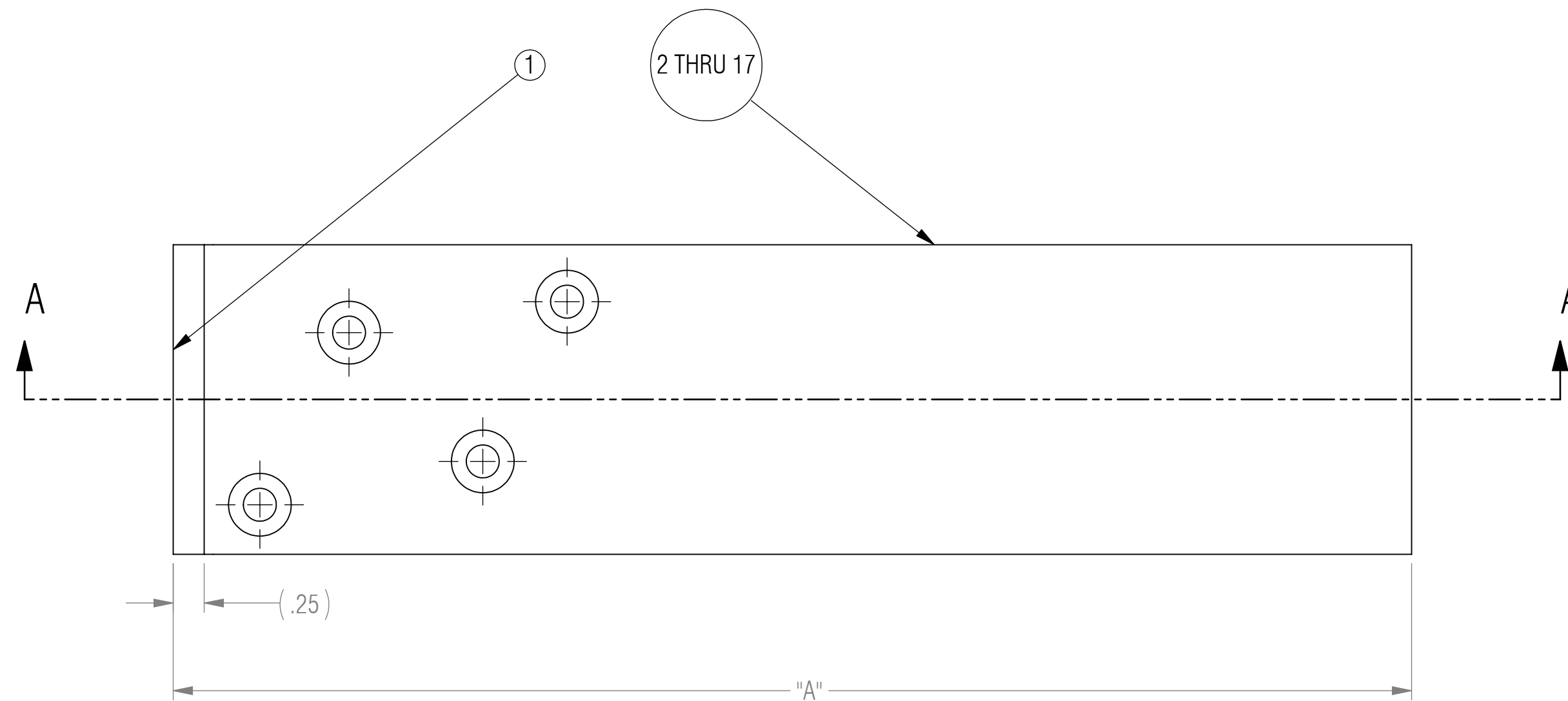

SECTION A-A

CONFIGURATION TABLE	
	"A"
CSA-0008-7	7.00
CSA-0008-8	8.00
CSA-0008-9	9.00
CSA-0008-10	10.00
CSA-0008-11	11.00
CSA-0008-12	12.00
CSA-0008-13	13.00
CSA-0008-14	14.00
CSA-0008-15	15.00
CSA-0008-16	16.00
CSA-0008-17	17.00
CSA-0008-18	18.00
CSA-0008-19	19.00
CSA-0008-20	20.00
CSA-0008-21	21.00
CSA-0008-22	22.00

RELEASED

UNLESS OTHERWISE SPECIFIED: DIMENSIONS ARE IN INCHES		ENGINEER		 A CENTERLINE STEEL, LLC DIVISION
TOLERANCES ARE:		ENGINEER		
ANGLES		ENGINEER		
.XX ± .01	XX° ± 1°	CHECKED	CAS 07/28/2013	
.XXX ± .005		DRAWN	KRH 07/28/2013	
INTERPRET DRAWINGS IN ACCORDANCE WITH:		MANAGER APPROVAL		THE INFORMATION ON THIS DRAWING IS PROPRIETARY AND SHALL NOT BE DISCLOSED, USED, OR DUPLICATED FOR PROCUREMENT OR MANUFACTURING PURPOSES WITHOUT THE EXPRESS WRITTEN CONSENT OF CENTERLINE STEEL, LLC
ASME Y14.100 ENGINEERING DRAWING PRACTICES	ASME Y14.38 ABBREVIATIONS	THIRD ANGLE PROJECTION		
ASME Y14.5 DIMENSIONING AND TOLERANCING	ASME Y14.6 SCREW THREAD REPRESENTATION			SIZE D SCALE 1:1
ASME Y14.8 CASTINGS, FORGINGS & MOLDED PARTS	AWS A2.4 WELDING SYMBOLS	DRAWING NO. CSA-0008		REV X1
IEEE STD 315 SYMBOLS FOR ELECTRICAL AND ELECTRONIC DIAGRAMS		SHEET 1 OF 2		

BOM TABLE																	
ITEM NO.	PART NUMBER	CSA-0008-7/QTY.	CSA-0008-8/QTY.	CSA-0008-9/QTY.	CSA-0008-10/QTY.	CSA-0008-11/QTY.	CSA-0008-12/QTY.	CSA-0008-13/QTY.	CSA-0008-14/QTY.	CSA-0008-15/QTY.	CSA-0008-16/QTY.	CSA-0008-17/QTY.	CSA-0008-18/QTY.	CSA-0008-19/QTY.	CSA-0008-20/QTY.	CSA-0008-21/QTY.	CSA-0008-22/QTY.
1	CSP-0016	1	1	1	1	1	1	1	1	1	1	1	1	1	1	1	1
2	CSP-0015-6.75	1	-	-	-	-	-	-	-	-	-	-	-	-	-	-	-
3	CSP-0015-7.75	-	1	-	-	-	-	-	-	-	-	-	-	-	-	-	-
4	CSP-0015-8.75	-	-	1	-	-	-	-	-	-	-	-	-	-	-	-	-
5	CSP-0015-9.75	-	-	-	1	-	-	-	-	-	-	-	-	-	-	-	-
6	CSP-0015-10.75	-	-	-	-	1	-	-	-	-	-	-	-	-	-	-	-
7	CSP-0015-11.75	-	-	-	-	-	1	-	-	-	-	-	-	-	-	-	-
8	CSP-0015-12.75	-	-	-	-	-	-	1	-	-	-	-	-	-	-	-	-
9	CSP-0015-13.75	-	-	-	-	-	-	-	1	-	-	-	-	-	-	-	-
10	CSP-0015-14.75	-	-	-	-	-	-	-	-	1	-	-	-	-	-	-	-
11	CSP-0015-15.75	-	-	-	-	-	-	-	-	-	1	-	-	-	-	-	-
12	CSP-0015-16.75	-	-	-	-	-	-	-	-	-	-	1	-	-	-	-	-
13	CSP-0015-17.75	-	-	-	-	-	-	-	-	-	-	-	1	-	-	-	-
14	CSP-0015-18.75	-	-	-	-	-	-	-	-	-	-	-	-	1	-	-	-
15	CSP-0015-19.75	-	-	-	-	-	-	-	-	-	-	-	-	-	1	-	-
16	CSP-0015-20.75	-	-	-	-	-	-	-	-	-	-	-	-	-	-	1	-
17	CSP-0015-21.75	-	-	-	-	-	-	-	-	-	-	-	-	-	-	-	1

SIZE	CAGE CODE	DRAWING NO	REV
D		CSA-0008	X1
SCALE	1:1		SHEET 2 OF 2