

Installation Guide | Standard, Standard Plus, & Forward L Brackets

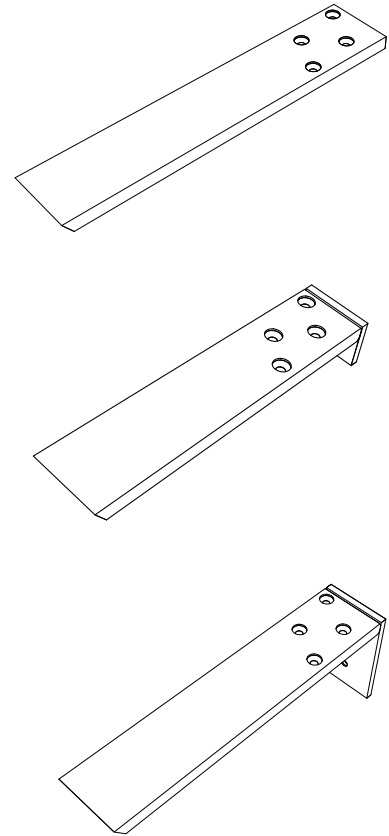
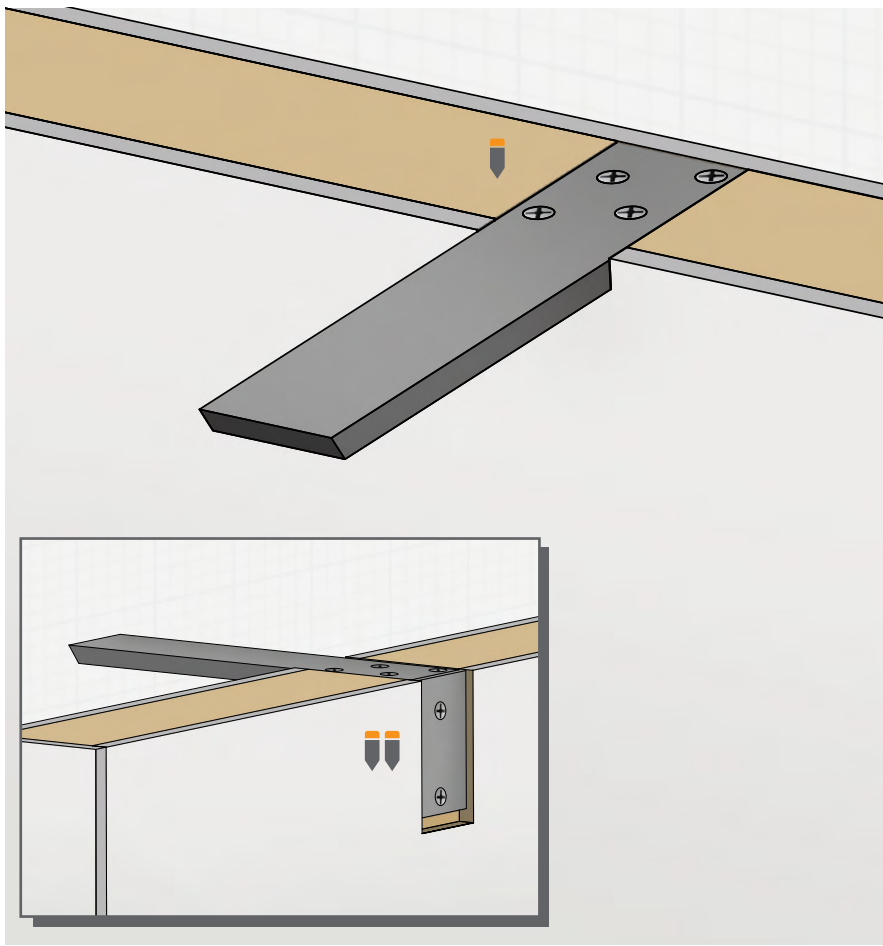

1. Measure and mark the appropriate mounting locations on the cap of your knee wall. Start at 6" inches in from the edges and space remaining brackets 18" - 24" apart.
 2. Create mounting channel for bracket:
 - A. **POWER TOOLS:** Use a Top Bearing Flush Trim router with a 1/2" deep cutting length and trim the excess wood out of the mounting surface.
 - B. **MANUAL TOOLS:** Use a hand saw and cut along each line to a depth of 1/2". Then using a wood chisel (1" is a good choice) to remove the excess wood between the lines you just created.
- NOTE:** Be sure to remove all the material in the mounting channel so you have a clean, level channel for the bracket to be seated in.
3. Place the bracket into the mounting channel and affix the bracket to the cap using ALL of the included screws. Drilling pilot holes in advance will help ensure the wood doesn't split.
 4. Use a level to ensure the brackets are level with the knee wall. If necessary, use shims to make the bracket level.
 5. Prior to setting the top in place, run a bead of high quality silicone adhesive down the center of each bracket.
- ADDITIONAL STEP FOR STANDARD PLUS AND FORWARD L BRACKETS:**
Screw the flange to the backside cap of the knee wall. The Forward L flange will also screw into the vertical stud.